

PFB300S

Wall Mount Bracket



Features

- Material: Aluminum
- Wall Mount Bracket
- Neat & Integrated design

Specifications

Model	PFB300S
General	
Material	Aluminum
Dimension (W x H x D)	115mmx 160mm x 228mm
Pipe Thread	G1 1/2"
Operating Temperature	-40°C ~60°C
Humidity	0~90% RH
Load Bearing	3.0Kg
Weight	0.49Kg
Applicable Model	Please see "Accessory Selection"

PFB300S

Dimensions (mm)

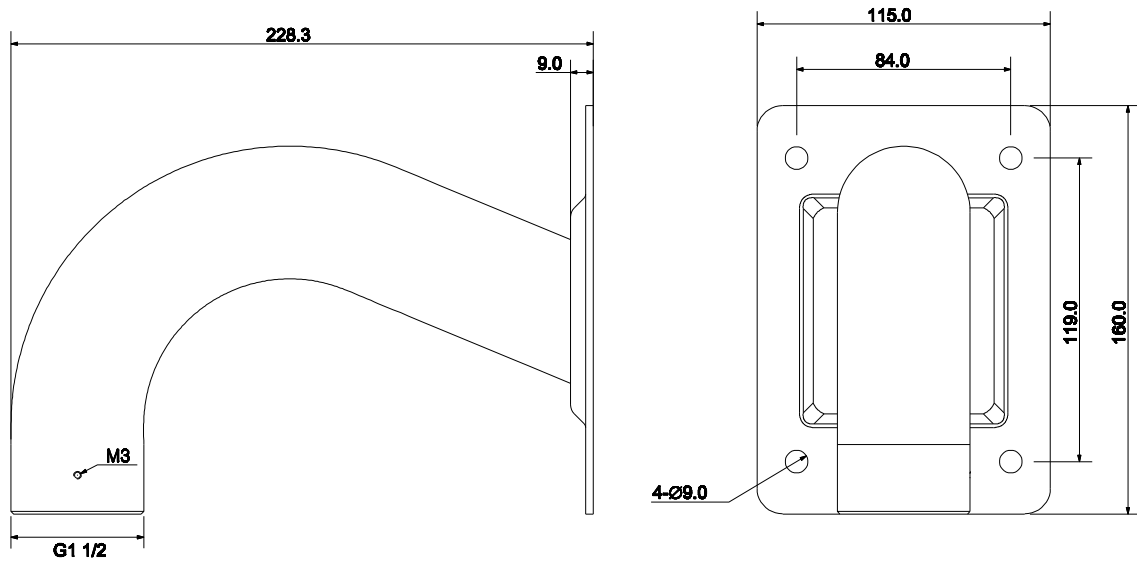

Application

